

ID
EAS
SHAR
ING

De Kossa



GAMBE, MENSOLE e/and SPECCHI.

ACCESSORI che fanno la differenza
/ ACCESSORIES that make the difference.

De Rosso si avvale di una collezione di accessori di design per corredare e armonizzare i suoi arredi.

De Rosso uses a design-accessories collection to supply and harmonize its furnishings.

Il repertorio di **GAMBE IN METALLO** è in grado di creare tavoli aventi forme, dimensioni e altezze diverse. Belle da vedere e tecnicamente perfette, sono previste per l'utilizzo con piani HPL o per piani in vetro.

The metal leg repertoire is able to create tables of different shapes, dimensions and various heights. Beautiful to see and technically perfect, they are organized for the use of Hpl and glass tops.

LE MENSOLE IN ALLUMINIO, DALLE LINEE NITIDE E RIGOROSE, creano scaffalature dove collocare oggetti e libri. Sono proposte nelle versioni a parete, in due profondità, o riposizionabili su montanti verticali.

THE ALUMINIUM SHELVES, WITH CLEAN AND STRINGENT LINES, create shelvings where can be placed objects and books. Proposed in the wall version, with two different depths, or repositionable on upright vertical columns.

GLI SPECCHI, disponibili in una varietà di dimensioni, sono incorniciati con eleganza da un sottile bordo di Alluminio.

MIRRORS available in different dimensions, are framed with elegance by a thin Aluminium frame.



MENSOLA | ID
EAS
SHAR
ING De Rosso



ID
EAS
SHAR
ING
De Rosso | MENSOLA

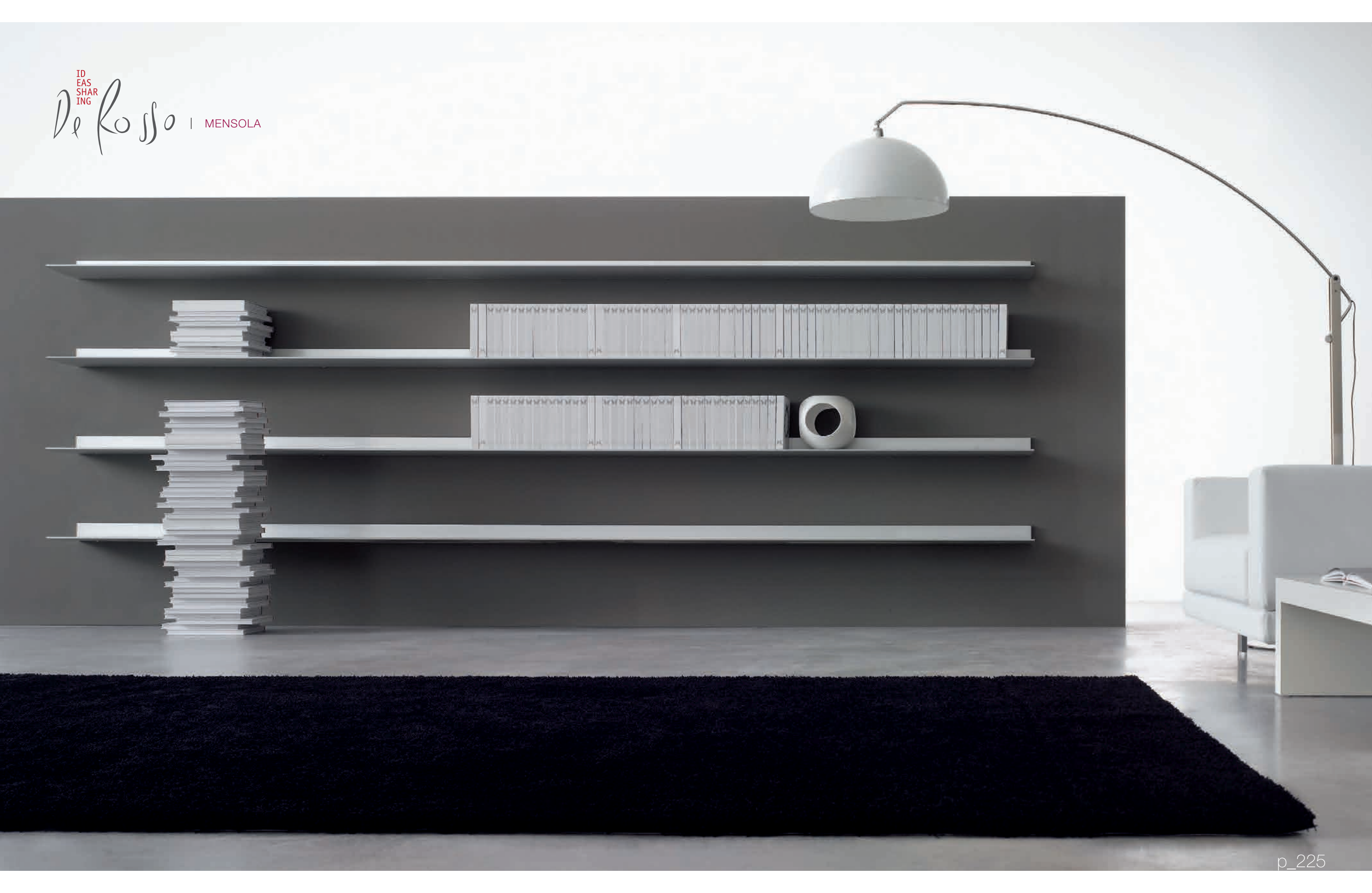





MENSOLE / Shelves.

MENSOLA / SHELF.

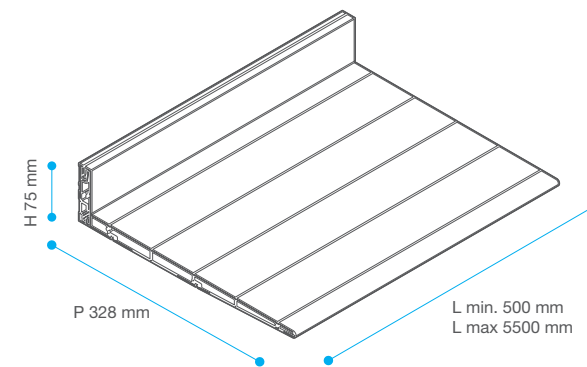
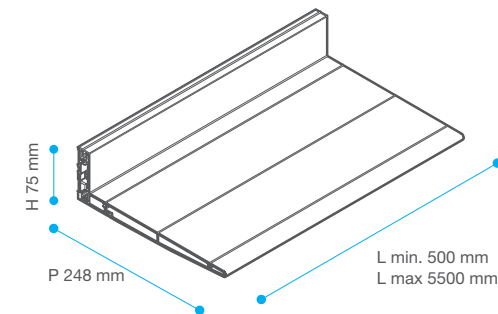

Tappi di chiusura laterali
Shelf end caps.

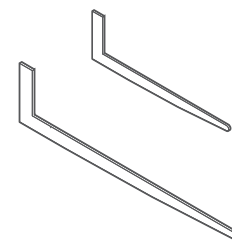

CLOK

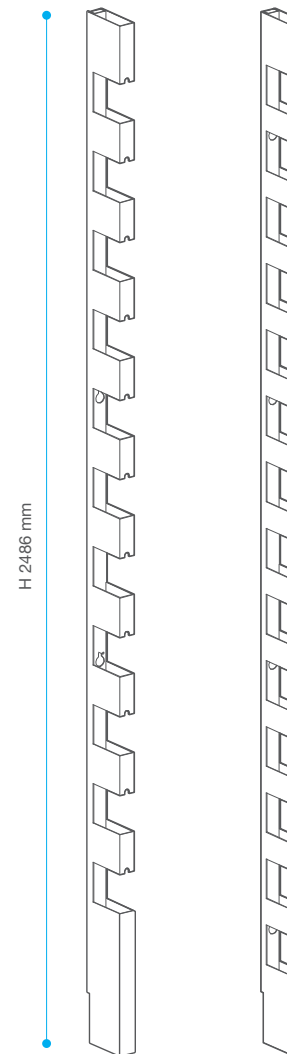

HR3

HR4

Coppia di supporti e tubo appendiabiti ovale
/ Pair of supports for oval clothes rail.



Blocco fissaggio piani sp. 28,5 / 39 mm
/ Fixing block for 28,5 / 39 mm thickness surfaces.



NOTE

- MENSOLA:**
- completa di supporti a parete
 - in Alluminio anodizzato
 - verniciata a polveri epossidiche

- A-KUMÈ:**
- completa di supporti a parete
 - in Alluminio anodizzato

- CLOK:**
- in lamiera di Acciaio 20/10
 - verniciata a polveri epossidiche

- / MENSOLA shelf:
- Wall mount supports included
 - Anodized Aluminium
 - Epoxy varnishing.

- / A-KUMÈ shelf:
- Wall mount supports included
 - Anodized Aluminium.

- / CLOCK shelf:
- 20/10 sheet steel rack
 - Epoxy varnishing.

A-KUMÈ

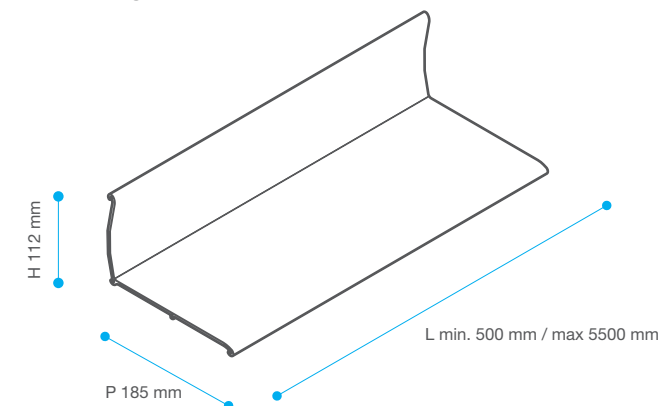

Tappi di chiusura laterali
/ End caps.

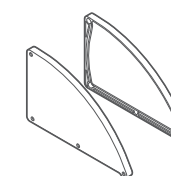

Separatori
/ Partitions.





SPECCHI / Mirrors.

ALTEZZA "H" E LARGHEZZA "L"
/ Height "H" and width "L".

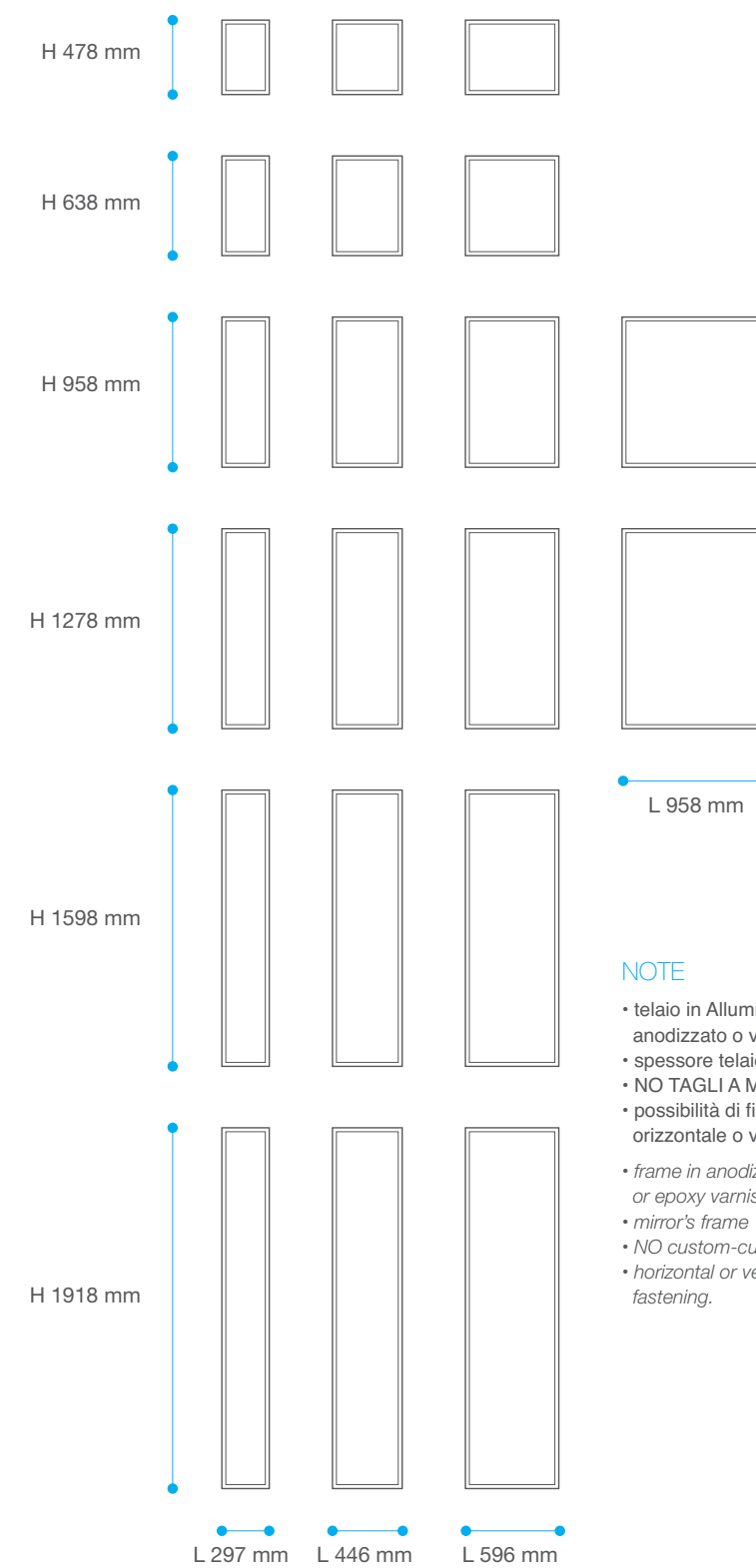

NOTE

- telaio in Alluminio anodizzato o verniciato
- spessore telaio 18,5 mm
- NO TAGLI A MISURA
- possibilità di fissaggio orizzontale o verticale.

- frame in anodized Aluminium or epoxy varnishing
- mirror's frame 18,5 thickness
- NO custom-cut
- horizontal or vertical fastening.

De Rosso

De Rosso Srl

Via Sernaglia 32/A,
31010 Farra di Soligo TREVISO Italy
T. +39 0438.9011 - F. +39 0438.900146
info@derosso.it

www.derosso.it

CONCEPTUAL PROJECT

Elisabetta GALLO

SPECIAL THANKS TO

Luciano MARSON

ART STYLIST

Annalisa BERARDI

supported by Adrian SCHIOPU

3D and PHOTO EDITING

Adrian SCHIOPU

PHOTOGRAPHY

IKON Gianni ANTONIALI / Sergio CHIMENTI /

Pino USICCO / Paolo RENIER /

Marco ALBERI AUBER /

Archivio DE ROSSO

IN PARTNERSHIP WITH

Abet Laminati

Printed in Italy by

IMOCO S.p.A.

I / I.MMXV

DE ROSSO SRL behält sich vor, jederzeit und ohne Vorankündigung alle Änderungen an den Modellen oder an den Geschäftsvereinbarungen vorzunehmen, die das Unternehmen im Hinblick auf die kontinuierliche Produktverbesserung für notwendig erachtet. Anhand dieser Änderungen werden die Geschäftsunterlagen regelmäßig überarbeitet. Irrtümer und/oder Druckfehler in diesem Katalog/dieser Preisliste sind kein Grund zur Beanstandung. Maßgebend ist immer die Auftragsbestätigung, die DE ROSSO SRL seinen Kunden sendet. Sollte DE ROSSO SRL beschließen, Auslaufartikel zu verlaufen, dann gilt: nur solange der Vorrat reicht. Gelistete Anbaulösungen werden so geliefert, wie sie im Katalog abgebildet sind, ohne Inneneinrichtung.

DE ROSSO SRL se réserve le droit d'apporter à tout moment et sans aucune obligation de préavis, toutes les modifications aux modèles ou aux accords commerciaux qu'il estimera opportun afin de pouvoir améliorer continuellement son produit. Ces modifications feront l'objet de révision périodique de la documentation commerciale. D'éventuelles erreurs et/ou refus d'impression du présent catalogue/liste de prix, ne constituent aucun motif de contestation. La confirmation de commande que DE ROSSO SRL enverra à ses clients fera foi. Lorsque l'entreprise décide de vendre des articles sujets à épuisement, l'engagement de DE ROSSO SRL devra être considéré comme étant une condition suspensive de la disponibilité effective de ces produits. Les compositions codifiées doivent être considérées fournies telles qu'elles sont visualisées dans le catalogue et dépourvues d'équipement interne.

www.derosso.it